

WALL INSULATION

Provide Moisture Control and Insulation in Wall Systems



Buildings for the 21st Century

Buildings that are more energy efficient, comfortable, and affordable...that's the goal of DOE's Office of Building Technology, State and Community Programs (BTS). To accelerate the development and wide application of energy efficiency measures, BTS:

- Conducts R&D on technologies and concepts for energy efficiency, working closely with the building industry and with manufacturers of materials, equipment, and appliances
- Promotes energy/money saving opportunities to both builders and buyers of homes and commercial buildings
- Works with state and local regulatory groups to improve building codes, appliance standards, and guidelines for efficient energy use
- Provides support and grants to states and communities for deployment of energy-efficient technologies and practices



EFFECTIVE WALL INSULATION

Properly sealed, moisture-protected, and insulated walls help increase comfort, reduce noise, and save on energy costs. However, walls are the most complex component of the building envelope to insulate, air seal, and control moisture.

The keys to an effective wall are:

- Airtight construction—all air leaks sealed in the wall during construction and prior to insulation installation.
- Moisture control—exterior rain drainage system, continuous air barrier, and vapor barrier located on the appropriate side of the wall.
- Complete insulation coverage—advanced framing to maximize insulation coverage and reduce thermal bridging, no gaps or compressed insulation, and continuous insulated sheathing.

AIR SEALING

Air sealing reduces heat flow from air movement (convection) and prevents water vapor in the air from entering the wall. In a 100-square-foot wall, one cup of water can diffuse through drywall without a vapor barrier in a year, but 50 cups can enter through a 1/2-inch, round hole. In fact, sealing air leaks is 10 to 100 times as important as installing a vapor barrier.

MOISTURE CONTROL

Air sealing and moisture control make insulation more effective. It is a myth that installing vapor barriers is the most important step for controlling moisture in walls. Vapor barriers only retard moisture due to diffusion, while most moisture enters walls either through fluid capillary action or as water vapor through air leaks.

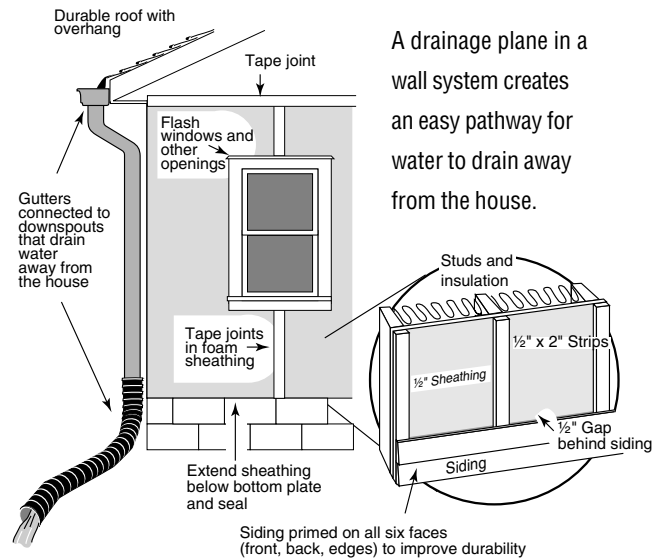

✓ PREVENT RAIN PENETRATION

Causes of rain leaks through exterior walls include improper installation of siding materials; poor-quality flashing, weatherstripping, or caulking around joints in the building exterior (such as windows, doors, and bottom plates); and wind-driven rain that penetrates the exterior finish. To enhance protection against rain penetration, create a drainage plane within the wall system of the home.

✓ CONTROL MOISTURE IN WALLS

All climates require these steps:

- Install a polyethylene ground cover on the earth floor of houses with crawl spaces and slope the ground away from the foundations of all houses.
- Install a continuous vapor barrier that has a Perm rating of less than one (see page 3).
- Place a termite shield, sill gaskets, or other vapor-impermeable membrane on the top of the foundation wall. This action will prevent moisture from wicking into the framed wall from the concrete foundation wall by capillary action.

WALL FRAMING WITH ADVANCED FRAMING TECHNIQUES

Building experts have performed considerable research on ways to reduce the amount of lumber in our homes while maintaining structural integrity. The U.S. Forestry Products Association and other organizations have devised an “optimum value engineering” (OVE) framing system that reduces unnecessary lumber use and improves the whole-wall R-value by reducing thermal bridging and maximizing the wall area that is insulated. Selected OVE practices include:

- Design the house to use materials efficiently by employing simpler shapes and volumes, compact designs, and designs based on a 2-foot module.
- Frame at 24-inch rather than 16-inch centers.
- Design headers for loading conditions and use insulated headers.
- Locate window and door openings in-line with established framing and size windows to fit within existing stud spacing.
- Eliminate unnecessary framing at intersections using two-stud rather than three-stud corners and ladder blocking where interior partitions intersect exterior walls.
- Use let-in bracing to allow the use of insulated sheathing in corners.
- Eliminate curtailed studs (cripples) under windows.
- Align roof, wall, and floor framing members (studs and joists) vertically throughout the structure so that a single top plate can be used.

INSULATED HEADERS AND LET-IN BRACING

Insulated headers

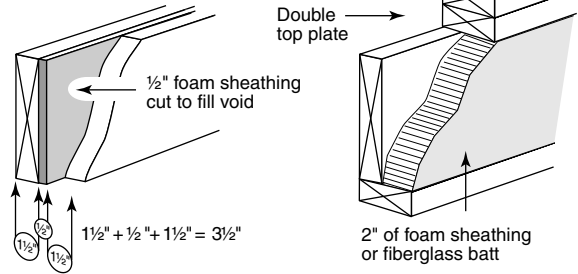

Let-in bracing

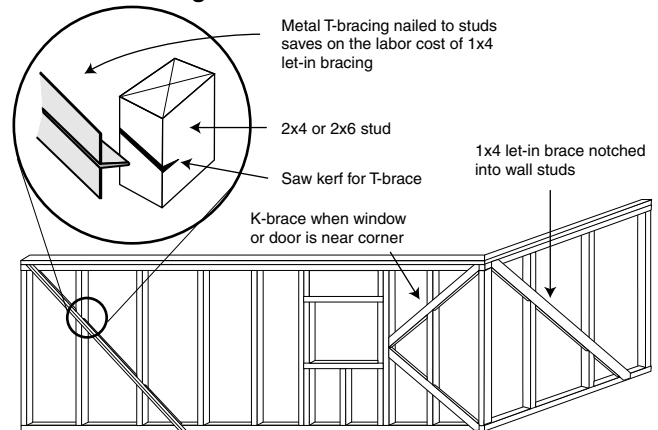

2X6 WALL CONSTRUCTION

In most code jurisdictions, 2x6's can be spaced on 24-inch centers, rather than 16-inch centers used for 2x4's. The advantages of using 2x6 studs on 24-inch centers are:

- The thicker wall cavity provides room for R-19 or R-21 wall insulation.
- Overall, thermal bridging through studs is reduced due to the higher R-value of 2x6's and less stud area in the wall.
- Less framing reduces labor costs.
- There is more space for insulating around piping, wiring, and ductwork.

The economics of 2x6 wall construction is favorable primarily in areas with significant winters and homes in which windows and doors occupy 10 percent or less of the total wall area. Walls with substantial window and door area may require almost as much framing as 2x4 walls because each opening can add extra studs. Additionally, the window and door jambs must be wider, requiring the purchase of a jamb extender that increases costs by \$12 to \$15 per opening.

Thicker insulated sheathing may be a less expensive way to increase overall R-value than 2x6 construction, especially in

STANDARD FRAMING VERSUS ADVANCED FRAMING CROSS-SECTION

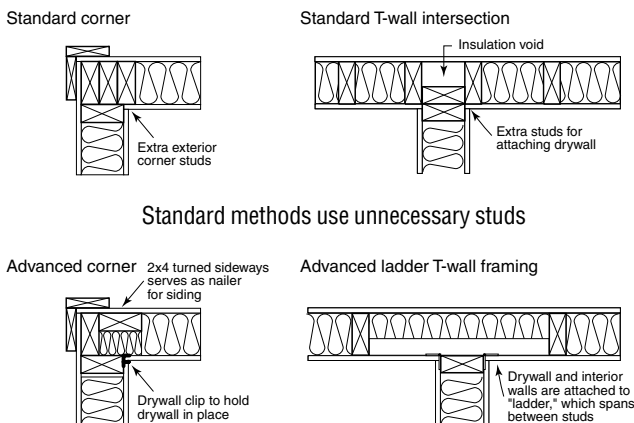

Comparison	Standard	Advanced
Insulation Voids	3%	0%
Framing factor	15-25%	10-15%
Batt R-value	R-13	R-13
Sheathing R-value	R-0.5 to 2.0	R-2.5
Effective Average R-value	R-11.1	R-14.6 (30% higher)

WALL INSULATION

homes with more window and door area. Another factor to consider is that the interior finish or exterior siding may bow slightly between studs when using 24-inch centers.

WHAT TYPE OF INSULATION SHOULD I USE?

The home designer has an increasing array of insulation products from which to choose to insulate wood-framed walls. The wide variety of insulation materials often makes it difficult to determine the most cost-effective products and techniques. Refer to the Model Energy Code (MEC) or DOE Insulation Fact Sheet for R-value recommendations for your climate and building type. The DOE Insulation Fact Sheet (DOE/CE-0180) can be ordered from the Energy Efficiency and Renewable Energy Clearinghouse or accessed from the Internet at www.ornl.gov/roofs+walls.

- *Fiberglass and rock wool batts*—2x4 walls can hold R-13 or R-15 batts; 2x6 walls can have R-19 or R-21 products. Generally, batt insulation is the least expensive wall insulation material but requires careful installation for effective performance (see page 4).
- *Cellulose insulation*, made from recycled newsprint, comes primarily in loose-fill form. It can be installed in walls using a dry-pack process or a moist-spray technique. It generally costs more than batt insulation, but it offers reduced air leakage through the wall cavity plus improved sound deadening.
- *Fiberglass and rock wool loose-fill insulation* provide full coverage with a “Blow-in Blanket” System (BIBS) that involves blowing insulation into open stud cavities behind a net.
- *Rigid foam insulation* has a higher R-value per inch than fiberglass or cellulose and stops air leaks, but it is considerably more expensive. It is manufactured in sheet-good dimensions and is often used as the outer layer of insulation.

- *Foam-in-place insulation* can be blown into walls and reduces air leakage. Some types use carbon dioxide in the manufacturing process rather than more environmentally harmful gases such as pentane or hydrochlorofluorocarbons.

WALL SHEATHINGS

Some builders use ½-inch wood sheathing (R-0.6) or asphalt-impregnated sheathing, usually called blackboard (R-1.3), to cover the exterior framing before installing siding. Instead, consider using ½-inch foam insulated sheathing (R-2 to R-3.5). Sheathing thicker than ½ inch will yield even higher R-values.

Foam sheathing has these advantages:

- The continuous layer of insulation reduces thermal bridging through wood studs, saving energy and improving comfort.
- It is easier to cut and install than heavier weight sheathing products.
- It protects against condensation on the inside wall by keeping the interior of the wall warmer.
- It usually costs less than plywood or oriented strand board (OSB).

Ensure that the sheathing completely covers, and is sealed to, the top plate and band joist at the floor. Most sheathing products come in 8-, 9-, or 10-foot lengths to allow complete coverage of the wall. Once it is installed, patch all holes, penetrations, and seams with caulk or housewrap tape.

Because of its insulation advantages over plywood and OSB, foam sheathing is best when used continuously in combination with let-in bracing, which provides structural support similar to that offered by plywood or OSB. Some builders use two layers of sheathing—plywood or OSB for structural support and a seam-staggered layer of rigid foam for insulation. When the total depth of the sheathing material exceeds ½ inch, make certain the window and door jambs are adjusted for the total wall thickness. Some flanged windows are readily adaptable to this approach.

VAPOR BARRIER PLACEMENT BY GEOGRAPHICAL LOCATION

In most cold climates, vapor barriers should be placed on the interior (warm-in-winter) side of walls. However, the map shows that in some southern climates, the vapor barrier should be omitted, while in hot and humid climates, such as along the Gulf coast and in Florida, the vapor barrier should be placed on the exterior of the wall.

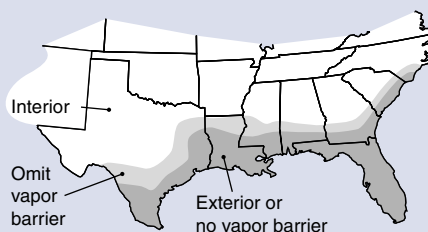

Perm Ratings of Different Materials

(Rating of 1 or less qualifies as a vapor barrier)

Asphalt-coated paper backing on insulation	0.40
Polyethylene plastic (6 mil)	0.06
Plywood with exterior glue	0.70
Plastic-coated insulated foam sheathing	0.4 to 1.2
Aluminum foil (.35 mil)	0.05
Vapor barrier paint or primer	0.45
Drywall (unpainted)	50
Drywall (painted - latex paint)	2-3

WALL INSULATION

For more information, contact:

Energy Efficiency and Renewable Energy Clearinghouse (EREC)
1-800-DOE-3732
www.eren.doe.gov

Or visit the BTS Web site at
www.eren.doe.gov/buildings

Or refer to the Builder's Guide Energy Efficient Building Association, Inc.
651-268-7585
www.eeba.org

Written and prepared for the U.S. Department of Energy by:

Southface Energy Institute
404-872-3549
www.southface.org

U.S. Department of Energy's Oak Ridge National Laboratory
Buildings Technology Center
423-574-5178
www.ornl.gov/ORNL/BTC

The Model Energy Code can be obtained from the International Code Council by calling 703-931-4533

MECcheck, a companion compliance software package, can be ordered from DOE by calling 1-800-270-CODE or downloaded directly from the Web at www.energycodes.org/resid/resid.htm.

NOTICE: Neither the United States government nor any agency thereof, nor any of their employees, makes any warranty, express or implied, or assumes any legal liability or responsibility for the accuracy, completeness, or usefulness of any information, apparatus, product, or process disclosed. The views and opinions of authors expressed herein do not necessarily state or reflect those of the United States government or any agency thereof.

STEPS FOR EFFECTIVE WALL CONSTRUCTION AND INSULATION

1. Review the plans and specifications and identify all walls (including bandjoists) between conditioned (heated and cooled) spaces and unconditioned spaces (exterior, attics, crawl spaces, garages, and mechanical rooms). Use advanced framing techniques to increase insulation levels and reduce lumber use.
2. Use diagonal corner bracing (let-in bracing) on exterior walls to substitute for corner plywood sheathing and allow continuous insulated sheathing.
3. Use foam sheathing for insulating headers to reduce framing heat loss.
4. Seal all air leaks through walls before insulating, including under the bottom plate, band joist areas between floors, electrical boxes, and all electrical, plumbing, and HVAC penetrations.
5. Use caulk and backer rod or non-expanding spray foam, not insulation, to seal around window and door jambs.
6. If fixtures such as stairs or shower/tub enclosures cover exterior walls and do not allow easy installation of insulation after the sheathing is attached, insulate behind these components in advance using R-13 or R-19 batts and cover with a weatherproof barrier (½-inch drywall, plastic, or other sheet material).
7. Select insulation levels based on the MEC and the DOE Insulation Fact Sheet.
8. Face-staple batts because side stapling creates channels for air flow and compresses the insulation, thus reducing the R-value. If face stapling is not an option, use unfaced batts or carefully side staple within ¼ inch of the stud face.

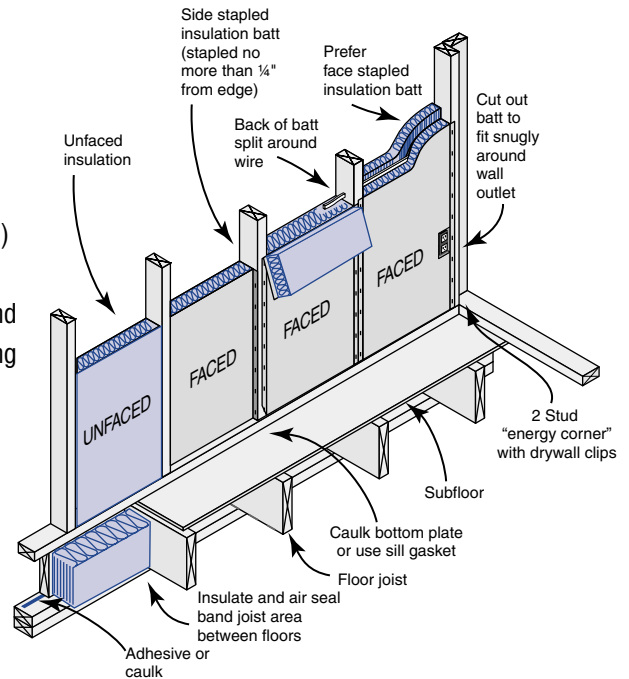

9. Obtain full coverage of batt or blown wall insulation. Cut batt insulation to fit snugly into non-standard stud spaces and to completely fill cavity.
10. Slit batt insulation to fit around the back and front side of electrical wiring and plumbing without compressing or tearing the insulation.
11. Notch out batt insulation around electrical boxes and use scraps to insulate behind the box.
12. Once the interior drywall is in place, seal all penetrations with durable caulking.

Fiberglass Batt Insulation Characteristics

Thickness (inches)	R-value	Cost (¢/sq.ft.)
3½	11	12-16
3¾	13	15-20
3½	15 (high density)	34-40
6 to 6¼	19	27-34
5¼	21 (high density)	33-39
8 to 8½	25	37-45
8	30 (high density)	45-49
9½	30 (standard)	39-43
12	38	55-60

This chart is for comparison only. Determine actual thickness, R-value, and cost from manufacturer or local building supply.



Printed with a renewable-source ink on paper containing at least 50% wastepaper, including 20% postconsumer waste.

October 2000 DOE/GO-102000-0772