

WINDOW SELECTION

Modern windows provide energy savings, durability, and comfort



Buildings for the 21st Century

Buildings that are more energy efficient, comfortable, and affordable... that's the goal of DOE's Building Technologies Program.

To accelerate the development and wide application of energy efficiency measures, the Building Technologies Program:

- Conducts R&D on technologies and concepts for energy efficiency, working closely with the building industry and with manufacturers of materials, equipment, and appliances
- Promotes energy/money saving opportunities to both builders and buyers of homes and commercial buildings
- Works with state and local regulatory groups to improve building codes, appliance standards, and guidelines for efficient energy use

WHY ARE WINDOWS IMPORTANT?

Windows bring light, warmth, cooling breezes, and beauty into homes and give a feeling of openness and space to living areas. Although beneficial, windows can negatively impact a home's energy efficiency, comfort, indoor air quality, and durability if not properly selected and installed.

Windows can be major sources of heat loss in the winter and heat gain in the summer. In cold climates, windows can be responsible for 10 to 25 percent of a home's heat loss during the winter and heat gain in the summer. While energy-efficient windows cost more than standard models, they can cut energy bills significantly and reduce heating and cooling loads enough to permit smaller and cheaper heating and cooling equipment and ductwork.

Energy-efficient windows improve comfort in the winter by increasing surface temperatures and by being more airtight, both of which cut drafts. Increased surface temperatures also reduce condensation that forms on the inside frame and glazing during the winter, protecting building materials and reducing mold growth.

High-performance, energy-efficient windows usually use multiple glazings and insulated frames, which reduce unwanted noise from the outside. Another window technology — low-emittance coating — blocks up to 98 percent of the ultraviolet radiation from the sun, reducing fading and wear on curtains, carpeting, and furniture.

STEPS TO WINDOW SELECTION

When properly selected and installed, windows can help minimize a home's heating, cooling, and lighting costs. Achieving improved window performance in a house is a three-step process:

- **Design** — Window sizes, types, placement, and properties should be determined as an integral part of the whole house design because of their impact on heating and cooling loads, lighting, and interior decor. Passive solar features and their impact on the windows should be considered during design. Window properties that meet the design goals should be specified using applicable guidelines.
- **Selection** — Windows should be selected that meet the specified design properties after considering the window technologies that improve performance and factoring in appearance, purchase price, cost of installation, warranty coverage, maintenance, replacement frequency, need for extra window treatments (like awnings), and resale value.
- **Installation** — Even the most energy-efficient window must be properly installed to ensure that its energy performance is achieved and that the window does not contribute to building moisture problems.

WINDOW LABELING

Look for these labels to guide your window purchase decisions.





National Fenestration
Rating Council

World's Best Window Co.

Millennium 2000+ Casement
Vinyl-Clad Wood Frame
Double Glaze • Argon Fill • Low E

CERTIFIED ENERGY Performance

* Energy savings will depend on your specific climate, house and lifestyle
 ** For more information, call (manufacturer's phone number) or visit NFRC's website at www.nfrc.org

Technical Information			
Heat Loss (U-Factor)	Visible Light (VT-CL)	Ultraviolet Light (Ultraviolet)	Shading Coefficient (SC)
Winter: 0.32	Summer: 0.45	Summer: 0.58	Summer: 0.3
Winter: 0.31	Summer: 0.45	Summer: 0.60	Summer: 0.3

Temperature (18°C) and Humidity (50%) are used for all NFRC window ratings. All NFRC ratings are determined to a fixed set of environmental conditions and specific procedures.



WINDOW PROPERTIES

Heat is lost and gained through windows by direct conduction through the glass and frame, by air leakage through and around the window assembly, and by the radiation of heat into the house (typically from the sun) and out of the house from room-temperature objects such as people, furniture, and interior walls.

The National Fenestration Rating Council (NFRC – 8484 Georgia Avenue, Suite 320, Silver Spring, Maryland 20910, 301-589-1776, www.nfrc.org) operates a voluntary certification program for windows that documents three measured criteria corresponding to each of these heat loss and gain methods: U-factor, air leakage, and solar heat gain coefficient (SHGC). In addition, NFRC labels the visible transmittance (VT) of the window.

- **U-factor** — U-factor is a measure of the rate at which a window conducts non-solar heat flow, usually expressed in units of Btu/hr-ft²-°F. The U-factor may refer to just the glass alone but, under the NFRC ratings, it represents the performance of the entire window, including the frame and spacer materials. A window with a lower U-factor is more energy-efficient than one with a higher U-factor. Window U-factors generally range from 0.2 to 1.2.
- **SHGC** — The SHGC is the fraction of solar radiation admitted through a window, either transmitted directly and/or absorbed by a window assembly and subsequently released as heat inside the home. The lower a window's SHGC, the less solar heat it transmits and the greater its shading ability. A window with a high SHGC is more effective at collecting solar heat gain during the winter. A window with a low SHGC is more effective at reducing cooling loads during the summer by blocking heat gained from the sun. SHGCs range between 0 and 1.
- **Air Leakage** — Air leakage is a measure of the rate of air infiltration around a window in the presence of a specific pressure difference across the window. The air leakage is expressed in units of cubic feet per minute per square foot of frame area (cfm/ft²). A window with a low air leakage rating is tighter than a window with a high air leakage rating. Air leakages are usually less than 1.
- **VT** — VT is the fraction of the visible spectrum of sunlight (380 to 720 nanometers) weighted by the sensitivity of the human eye that is transmitted through the window's glazing. A window with a higher VT transmits more visible light. VT is expressed as a number between 0 and 1.

Window selection is primarily based on U-factor and SHGC, although VT and air leakage can be important. Thus, the NFRC label helps consumers make educated purchasing decisions.

WINDOW DESIGN CONSIDERATIONS

Windows are an important element of passive solar designs, which can reduce heating, cooling, and lighting needs in a house. Given the proper building site, virtually any type of architecture can integrate at least some passive solar design features. Passive solar design strategies vary by building location and regional climate, but the basic techniques involving windows remain the same — select, orient, and size glass to maximize solar heat gain in winter and minimize it in summer, with different glazings usually selected for different sides of the house (exposures).

In heating climates, major glass areas are generally faced south to collect solar heat during the winter when the sun is low in the sky. In the summer, when the sun is high overhead, overhangs or other shading devices (e.g., awnings) prevent excessive heat gain. To be effective, south-facing windows usually must have a SHGC of greater than 0.6 to maximize solar heat gain during the winter, a U-factor of 0.35 or less to reduce conductive heat transfer, and a high VT for good visible light transfer.

Windows on east-, west-, and north-facing walls are reduced in heating climates, while still allowing for adequate daylight. East- and west-facing windows are limited because it is difficult to effectively control the heat and penetrating rays of the sun when it is low in the sky. These windows should have a low SHGC and/or be shaded. North-facing windows collect little solar heat, so they are used just to provide useful lighting.

In cooling climates, particularly effective strategies include preferential use of north-facing windows and generously shaded south-facing windows.

The type of window impacts the air leakage and effective natural ventilation that can be achieved. Fixed-pane windows are air-tight but are not suitable in places where ventilation is desired. Casement, awning, and hopper windows provide good ventilation when opened and are moderately air-tight when closed because they have compression seals. Sliding, double-hung, and single-hung windows are the most leaky and provide minimal ventilation when opened.

WINDOW TYPES

Energy-efficient windows come in traditional styles.

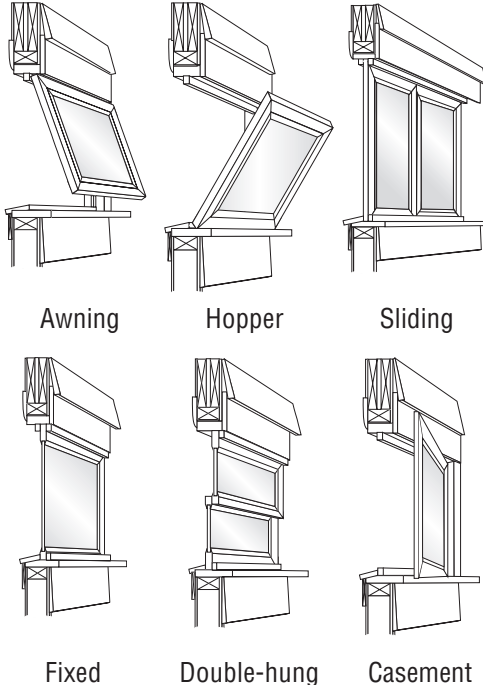

WINDOW SPECIFICATION GUIDELINES

There are three sources of guidance to help in the specification of windows. These should be used after considering the passive solar features that will be included in the house and the impact these have on the window requirements. Shading to be provided by landscaping, overhangs, shutters, etc., should also be considered, especially when focusing on the SHGC needed for the windows.

✓ 2000 INTERNATIONAL ENERGY CONSERVATION CODE

As a minimum, windows should be selected in accordance with the 2000 International Energy Conservation Code. The International Energy Conservation Code can be obtained from the International Code Council, 703-931-4533, www.intlcode.org. The U-factor required for a specific climate may be dependent on the window area being installed or the efficiency of other elements of the house depending on the compliance approach chosen. The air leakage rating must be less than 0.3, and the SHGC must be less than 0.4 if the heating-degree days are less than 3,500.

✓ ENERGY STAR®

Energy Star is a federal initiative that helps consumers identify energy-efficient products, including windows and skylights. Windows carrying the Energy Star label use less energy than standard products for three major climate regions across the country. All Energy Star windows must carry the NFRC certification label.

Information on the Energy Star windows program can be found at www.energystar.gov. The following are the Energy Star window qualification guidelines by climate group.

ENERGY STAR® FENESTRATION GUIDELINES

Climate	Window & Door		Skylight	
	U-factor	SHGC	U-factor	SHGC
Northern	0.35 or less	None specified	0.45 or less	None specified
Central	0.40 or less	0.55 or less	0.45 or less	0.55 or less
Southern	0.75 or less	0.40 or less	0.75 or less	0.40 or less

VT > 0.60 recommended in all climates.

✓ THE EFFICIENT WINDOWS COLLABORATIVE

The Efficient Windows Collaborative provides information on energy-efficient windows, including recommendations for product selection based on climate and state. Its website (www.efficientwindows.org) includes a regionally-designed window selection tutorial to guide consumers through NFRC and Energy Star window criteria. The tutorial includes comparisons of the annual energy performance of various window options for an average 2000-ft² house. Additional SHGC recommendations are provided compared with Energy Star criteria, and U-factor criteria are somewhat different for homes located in California.

WINDOW SELECTION

WINDOW INSTALLATION

Window installation varies depending on the type of house construction (wood versus masonry), exterior cladding (e.g., wood siding, stucco, brick), and type of weather-resistive barrier being installed. Windows should be installed following manufacturing recommendations and considering the following additional guidelines (primarily for windows with fin mounting systems).

The window opening must be flashed and integrated into the home's weather-resistive barrier so that any potential water leaks do not cause damage. A weather-resistive barrier is a drainage plane that allows water that has penetrated past the siding to drain away from the wall system. The figures illustrate a procedure when building paper or housewrap is being used as the weather-resistive barrier. Details will vary with siding and window type and the installation sequence for the window, trim, and weather-resistive barrier. It is advisable to install window

head and sill flashing, whether it is metal, plastic, or a self-sticking elastomeric membrane. Avoid relying on tapes or sealants to provide waterproofing, as these products may fail over time.

It is common practice and recommended by some manufacturers to cut an "X" in housewrap placed over window openings, pull the material inside, and secure it by stapling. Other manufacturers require alternative methods, such as the modified "I"-cut, depending on the overall flashing approach. The "I"-cut allows the vertical leg of the head flashing to be placed under the weather-resistive barrier and then taped or sealed.

It is best to divert drainage onto the face of the weather-resistive barrier. Do not tape down or seal behind the bottom nailing flange of the window, as doing so could accidentally trap in water.

FLASHING WINDOW OPENINGS

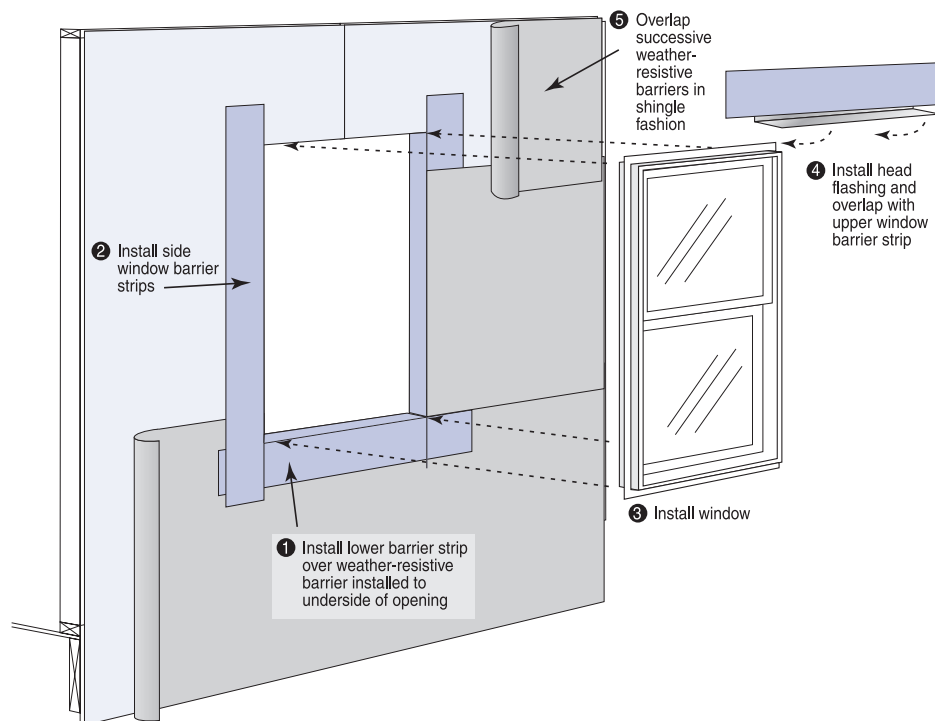

Create slits to slide head flashing and barrier strip underneath housewrap, fasten with nails, then tape the slits in the wrap

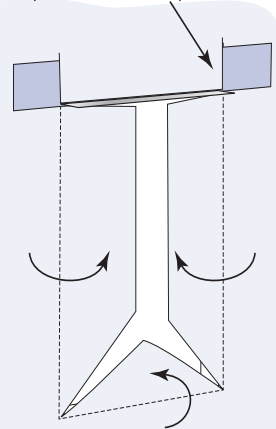

The modified "I"-cut wrap creates three flaps that are wrapped around the window opening

- Barrier strips are attached with nails and overlapped with successive barrier strips and weather-resistive barriers in shingle fashion. Do not depend on tapes or glues, as they may fail over time.

One housewrap technique utilizes a modified "I"-cut in the material over a window opening, which creates flaps that are then wrapped to the inside of the window frame and fastened. The head flashing and barrier strip are fastened and "shingled" under a flap that is cut in the housewrap. These seams are then taped.

WINDOW SELECTION

SEAL ROUGH OPENING

Use backer-rod and caulk or non-expanding foam sealant to fill the gaps around the window and rough opening.

Use backer rod to fill gaps between the window and rough opening before caulking

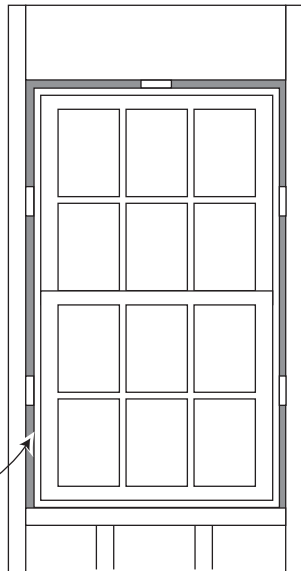

Windows must also be properly air-sealed during installation to perform correctly. To air seal the window, caulk the backsides of the window mounting flanges (top and sides only) to the weather-resistive barrier during installation. The mounting flange (nailing fin) is an integral part of most window frames that laps over the conventional stud construction. Nails are driven through it to secure the frame in place. Also, from inside the house, seal the gap between the window frame and rough opening using backer rod and caulk or non-expanding latex-based spray foams that will not pinch jambs or void window warranties. Backer rod is a closed-cell foam or rope caulk that is pressed into cracks or gaps with a screwdriver or putty knife. Insulation stuffed into this crack does not stop air flow.

WINDOW TECHNOLOGIES

A number of different window technologies improve the energy efficiency of windows and raise or lower the three primary window rating criteria: U-factor, SHGC, and VT.

- **Frame material:** Vinyl, wood, fiberglass, and some composite frame materials have a higher thermal resistance than metal window frames, so they lower the U-factor for the window. Metal window frames should have a thermal break (insulating plastic strip placed between the inside and outside of the frame and sash) to reduce heat flow and the window U-factor.

WINDOW TECHNOLOGIES

Energy-efficient window technologies are available to produce windows with the U-factor, SHGC, and VT properties needed for any application.

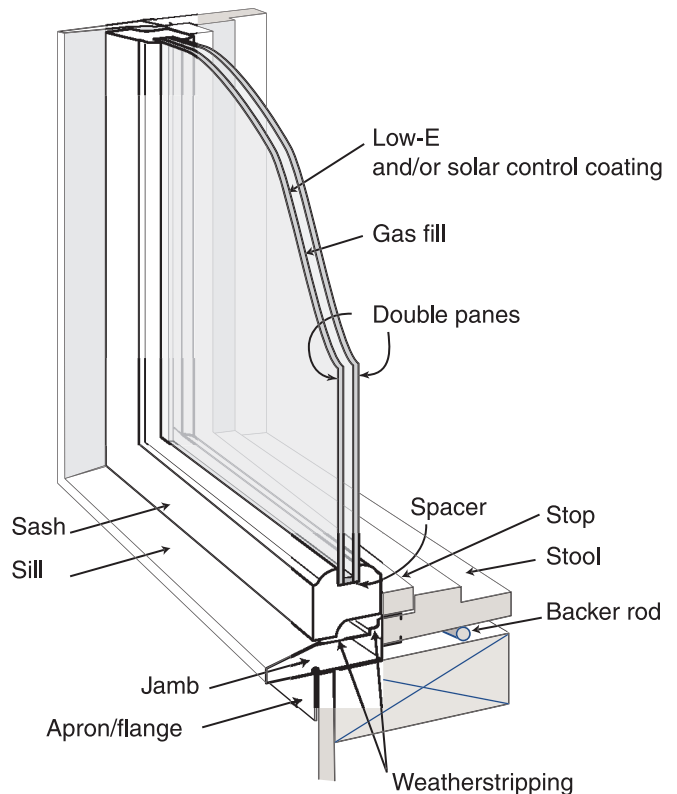

WINDOW SELECTION

For more information, contact:

Energy Efficiency and Renewable Energy Clearinghouse (EREC)
1-800-DOE-3732
www.eere.doe.gov

Or visit the Building Technologies Program Web site at www.buildings.gov

Or refer to the Residential Windows: A Guide to New Technology and Energy Performance, *Second Edition, Efficient Windows Collaborative*
www.efficientwindows.org

Written and prepared for the U.S. Department of Energy by:

Southface Energy Institute
404-872-3549
www.southface.org

U.S. Department of Energy's Oak Ridge National Laboratory
Buildings Technology Center
865-574-5206
www.ornl.gov/btc

NOTICE: Neither the United States government nor any agency thereof, nor any of their employees, makes any warranty, express or implied, or assumes any legal liability or responsibility for the accuracy, completeness, or usefulness of any information, apparatus, product, or process disclosed. The views and opinions of authors expressed herein do not necessarily state or reflect those of the United States government or any agency thereof.

- **Insulated glazing:** Insulated glazing (also called double glazing or triple glazing) refers to windows with two or more panes of glass. The glass panes are spaced apart and hermetically sealed to form a single glazed unit with an air space between each pane of glass. The glass layers and the air spaces resist heat flow. Insulated glazing's main impact is to lower the U-factor, but it also lowers the SHGC.
- **Spacer:** A spacer separates two panes of glass. Some spacers are designed to conduct heat less readily than others, which lowers the window U-factor.
- **Low-emittance coating:** A low-emittance (or low-e) coating is a microscopically thin, virtually invisible, metal or metallic oxide layer deposited directly on the surface of one or more of the panes of glass in a window with insulated glazing. The low-e coating reduces the infrared radiation from a warm pane of glass to a cooler pane, thereby lowering the U-factor of the window. Low-e coatings also reduce the SHGC and VT. To keep the sun's heat out of the house (for hot climates, east- and west-facing windows, and unshaded south-facing windows), the low-e coating should be applied to the outside pane of glass. If the windows are designed to provide heat energy in the winter and keep heat inside the house (typical of cold climates), the low-e coating should be applied to the inside pane of glass.
- **Spectrally selective coating:** A special category of low-e coating is spectrally selective. This coating is optically designed to reflect particular wavelengths and be transparent to others. Such a coating is commonly used to reflect the infrared (heat) portion of the solar spectrum but admit a higher portion of visible light, creating a window with a low U-factor and low SHGC, but a high VT.
- **Inert gas fill:** Inert gases are ones that do not react readily with other substances (e.g., argon, krypton). Because these gases have a higher resistance to heat flow than air, they (rather than air) are sealed between the window panes of windows with insulated glazing (and usually a low-e coating) to decrease a window's U-factor.
- **Heat-absorbing (or tinted) glass:** Heat-absorbing glass contains special tints that change the color of the glass. Tinted glass absorbs a large fraction of the incoming solar radiation, which reduces SHGC, VT, and glare. Gray and bronze tints reduce the penetration of both visible light and heat into buildings in equal amounts and are the most common colors used. Blue- and green-tinted windows offer greater penetration of visible light (higher VT) but also heat (higher SHGC). Heat-absorbing glass reflects only a small percentage of light and therefore does not have the mirror-like appearance of reflective glass.
- **Reflective glass:** Reflective glass is coated to reflect radiation striking the surface of the glass. The reflective coating usually consists of thin metallic layers and comes in various metallic colors (silver, gold, bronze). Reflective glass reduces the passage of solar radiation through the window, generally blocking more visible light than heat. It reduces SHGC and greatly reduces VT and glare. Reflective glass is most useful in hot climates in which solar control is critical, and it is usually used just for special applications. Reduced cooling energy demands may be offset by the need for additional electrical lighting.



Printed with a renewable-source ink on paper containing at least 50% wastepaper, including 20% postconsumer waste.

February 2003 DOE/GO-10099-777